

## Series 26 Low Water Cutoff – Standoff Mount

- ▶ Meets CSD1 Requirements
- ▶ Non Powered Contacts
- ▶ Time Delays Available
- ▶ LED Monitoring
- ▶ Test Feature
- ▶ AC Current Minimizes Electrolysis
- ▶ Snap-Thru Standoff Mounting
- ▶ Compact Size
- ▶ Power Outage Feature
- ▶ U.L. “Limit Control”

### Series 26 – General Purpose Control

Designed for boiler low-water cutoff protection. A snap-through standoff mounting device is available for Series 26 units. Optional Power Outage feature resets after nuisance outages. Optional reset button is used when device has been deactivated because of low water condition. Reset is functional only if water has returned to normal level. Optional Test Feature available allows LLCO circuit to be tested without draining the water level in the boiler. Built-in 3 second time delay is standard. Up to 90 seconds available for increasing and decreasing levels.

### Specifications

<b>Contact Design</b>	1 N.O. & 1 N.C. (1 form C)
<b>Contact Rating</b>	10 amp Resistive 1/3 hp at 120, 240 VAC
<b>Mode of Operation</b>	Direct
<b>Sensitivity</b>	0-100K ohm, factory set
<b>Primary Voltage</b>	120 VAC, 240 VAC <sup>1</sup> , 24 VAC, 208/240 VAC (+10%/-15%) 50/60 Hz
<b>Secondary Voltage</b>	12 VAC, 1.5 mA
<b>Temperature</b>	-40°F to +150°F (-40°C to +65°C)
<b>Approvals<sup>1</sup></b>	U.L. 353, U.L. 508 File # MP1430
<b>Terminal Style</b>	Spade connection
<b>Options</b>	Time Delays, Power Outage, Retrofit Plate, Test Feature, See page E-11 for descriptions

Notes:

1. 240 VAC and 208/240 VAC are not U.L. recognized

### How to Order

Use the **Bold** characters from the chart below to construct a product code.

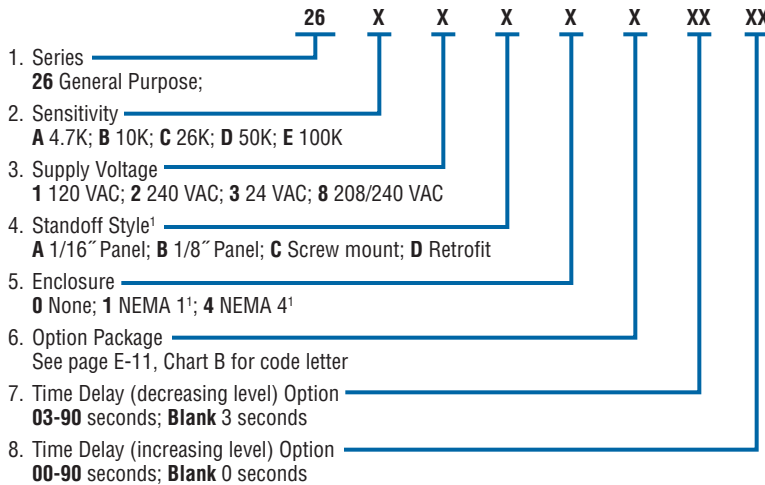

Notes:

1. Standoff Style D only.



### Applications

- Low-Water Cutoff
- Point Level
- Valve Control
- Single-Level Service
- Alarms
- Pump Control

### Dimensions

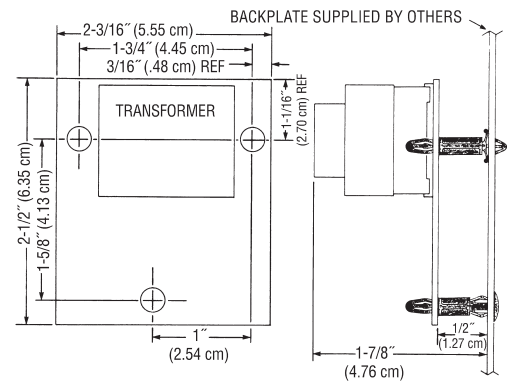

### Wiring

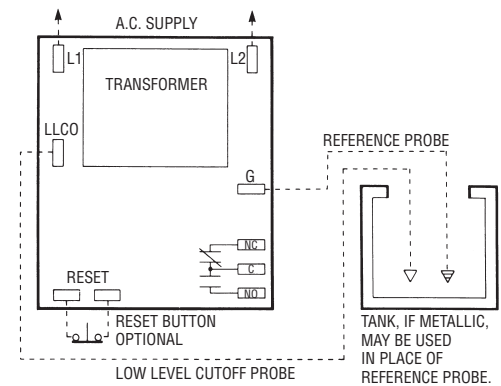

Socket Details and Option Availability are located on web site.

# Optional Character Reference – 16, 26 and DF Series Only

## Manual Reset

### Available on Series 26, 26M and DF controls

(Normally closed pushbutton across reset terminals. Pushbutton ordered separately): Manual reset only applies to the function associated with terminal LLCO. When the liquid rises to the electrode on terminal LLCO, the control will remain de-energized (load contacts in original state) until the pushbutton is depressed. The control will then energize, (LED will be lit) changing the state of the contacts. The control remains energized until the liquid level recedes below electrode on terminal LLCO. The control then de-energizes, (LED will go off) returning load contacts to their original state. Unless otherwise specified, there is a three second time delay on decreasing level. Liquid must be below probe on terminal LLCO for full three seconds before control de-energizes.

## Manual Reset with Power Outage Feature

### Available on Series 26, 26M, and DF controls

Reset (Normally closed pushbutton across reset terminals. Pushbutton ordered separately) Control will ignore power loss to control. With liquid in contact with electrode on terminal LLCO, a power outage will cause the control to de-energize, but will automatically energize upon return of power. However, loss of liquid will cause control to de-energize and remain so until liquid again rises to electrode and pushbutton is depressed.

## Time Delays Associated with Terminals H and L

### Available on Series 16, 16M, and DF controls

With time delay on increasing level, the liquid must be in contact with the high electrode for the full duration of the time delay before control will operate. With delay on decreasing level, the liquid must be below the low electrode for the full duration of the time delay before control will operate. In single level service, terminals 3 and 4 must be jumpered together to achieve time delays on both increasing and decreasing levels or just decreasing level.

## Time Delays Associated with Terminal LLCO

### Available on Series 26, 26M, and DF controls

3 Second time delay on decreasing level is standard. Delay up to 90 seconds, can be specified and would act in the same manner as listed above.

## Time Out Option

### Available on Series 16, 16M, and DF controls

The latching circuit for the high and low electrode has an optional timer. In some applications the High or Low electrode may become short circuited or disconnected. Such an occurrence may potentially over fill in fill applications, or cause the pump to run dry in pump down applications. The time option is custom programmed up to 3 minutes. When a fault condition occurs, the FILL LED will have a blink sequence of .5 seconds on 2 seconds off. See Chart A for time delay options.

## Test Feature

### Available on Series 26, 26M, and DF controls

Allows LLCO circuit to be tested. Holding down the reset button for 3 seconds will allow the LLCO circuit to trip which simulates the loss of water, without the need of draining the water level in the boiler. The control will return to normal operation once the reset button is pressed a second time. (Test feature option only available with the manual reset function.)

Chart A – Time Out Option

Optional Character	Time Out (in seconds)					
	30	60	90	120	150	180
K	•					
L		•				
M			•			
N				•		
P					•	
Q						•

Chart B – Optional Character Information

Reset Function	Option Components				Control Series	Optional Character
	Normally Closed Pushbutton*	Power Outage	Retrofit Plate	Test Feature		
•					DF "LLCO"	D
•	•				26, 26M, 26NM	C
•		•			26, 26M, 26NM	E
•			•		16, 16D, 26, DF	R
•	•				DF "LLCO"	S
•		•			DF "LLCO"	K
•			•		DF	W
•				•	26, 26M, 26NM, DF"LLCO"	B
•	•	•			26, 26M, 26NM	F
•		•	•		26	N
•	•	•			DF "LLCO"	G
•	•		•		DF	T
•	•			•	26, 26M, 26NM, DF"LLCO"	Y
•		•	•		DF	L
•		•		•	26, 26M, 26NM, DF"LLCO"	Z
•	•	•	•		26	P
•	•	•	•		DF	J
•	•	•		•	26, 26M, 26NM, DF"LLCO"	A
No options						X

\* N.C. pushbutton when purchased in conjunction with open control must be remotely mounted by customer